

Motor circuit breakers

Motor circuit breakers *Debut!*



MMP-T Series

Motor circuit breakers

Safety Warning

To ensure proper use of the products listed in this catalog, please be sure to read the instruction manual prior to use.

Mitsubishi Electric Corporation Nagoya Works is a factory certified for ISO14001 (standards for environmental management systems) and ISO9001(standards for quality assurance management systems)



ISO 9001
BUREAU VERITAS
Certification



 for a greener tomorrow

Eco Changes is the Mitsubishi Electric Group's environmental statement, and expresses the Group's stance on environmental management. Through a wide range of businesses, we are helping contribute to the realization of a sustainable society.

MITSUBISHI ELECTRIC CORPORATION
HEAD OFFICE: TOKYO BLDG., 2-7-3, MARUNOUCHI, CHIYODA-KU, TOKYO 100-8310, JAPAN

Bring a breath of fresh air into a Motor Control Circuit!

With Mitsubishi Electric's range of smart Motor circuit breakers!



Motor circuit breakers

MMP-T series



Customers' Needs	4
Outline of Motor circuit breakers	6
● What is a Motor circuit breaker?	6
● What is the role of a Motor circuit breaker?	7
● Why is a Motor circuit breaker required at this time?	8
Advantages of Adopting Motor circuit breakers	9
Specifications	12

Optional Unit	18
Outline Drawing	20
UL Standard and SCCR	26
About Warranty	29
Information of Our FA-related Products	30

Desire to down-size the machine control panels

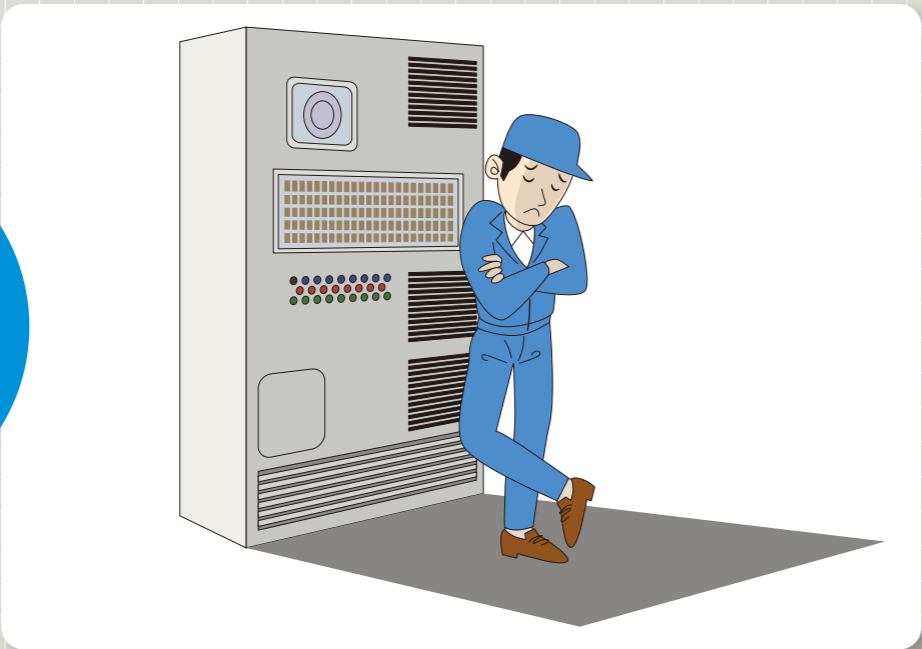

Desire to increase wiring efficiency

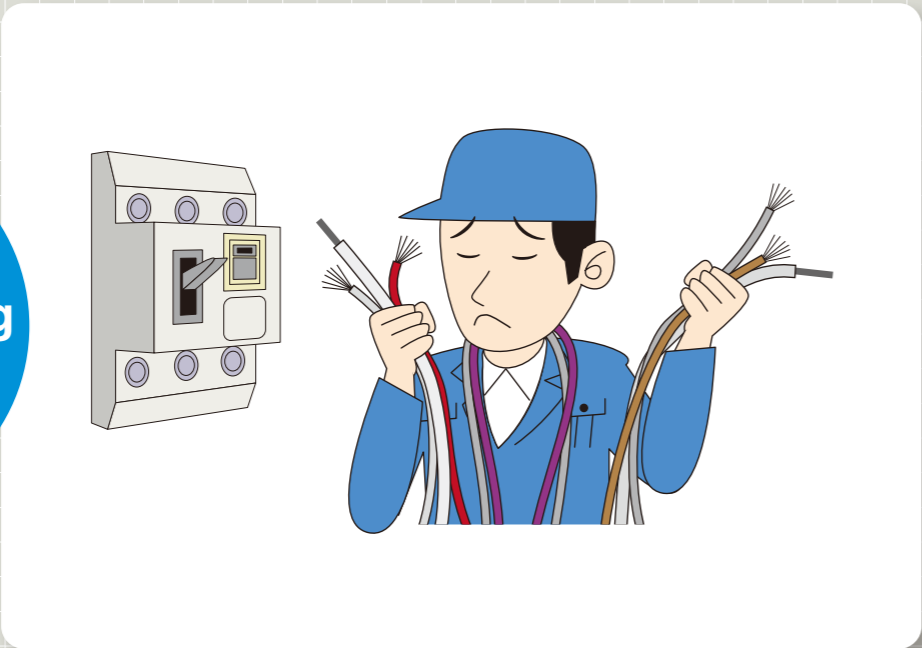

Desire to meet global demands



Do these requirements sound familiar?



The new MMP-T Series can help you solve these issues.



- S** Down-sizing
small
- S** Wiring reduction
smart wiring
- S** Safety & Quality
safety & Quality
- S** Worldwide coverage
Global standard



Outline

What is a Motor circuit breaker?

A Motor circuit breaker is a device integrating Low voltage circuit breakers and Thermal Overload Relays functions.

This device is capable of protecting the motor branch circuits from overload, phase-loss, and short-circuit alone. It enable even more secure wiring and motor protection.

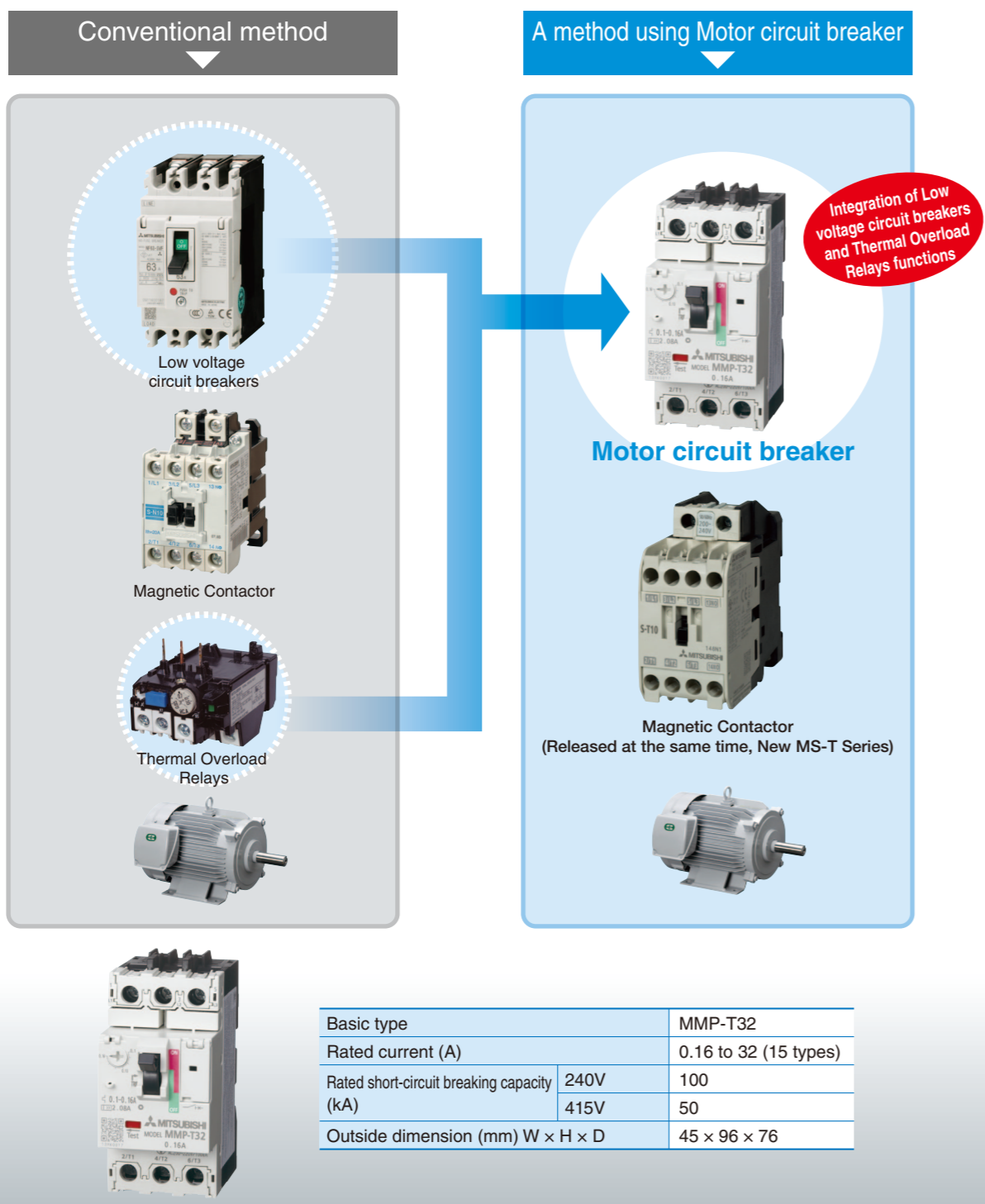

What is the role of a Motor circuit breaker in a motor circuit?

The motor circuit requires various roles, including disconnection, circuit on/off switching, short-circuit protection, device protection, motor control, and overload protection. A motor circuit consisting of a Low voltage circuit breakers, Magnetic Contactor, and Thermal Overload Relays is typically adopted and each of the devices has its own independent role. On the other hand, in a motor circuit consisting of a Motor circuit breaker and an Magnetic Contactor, only motor control is provided by the Magnetic Contactor and other functions are provided by the Motor circuit breaker.

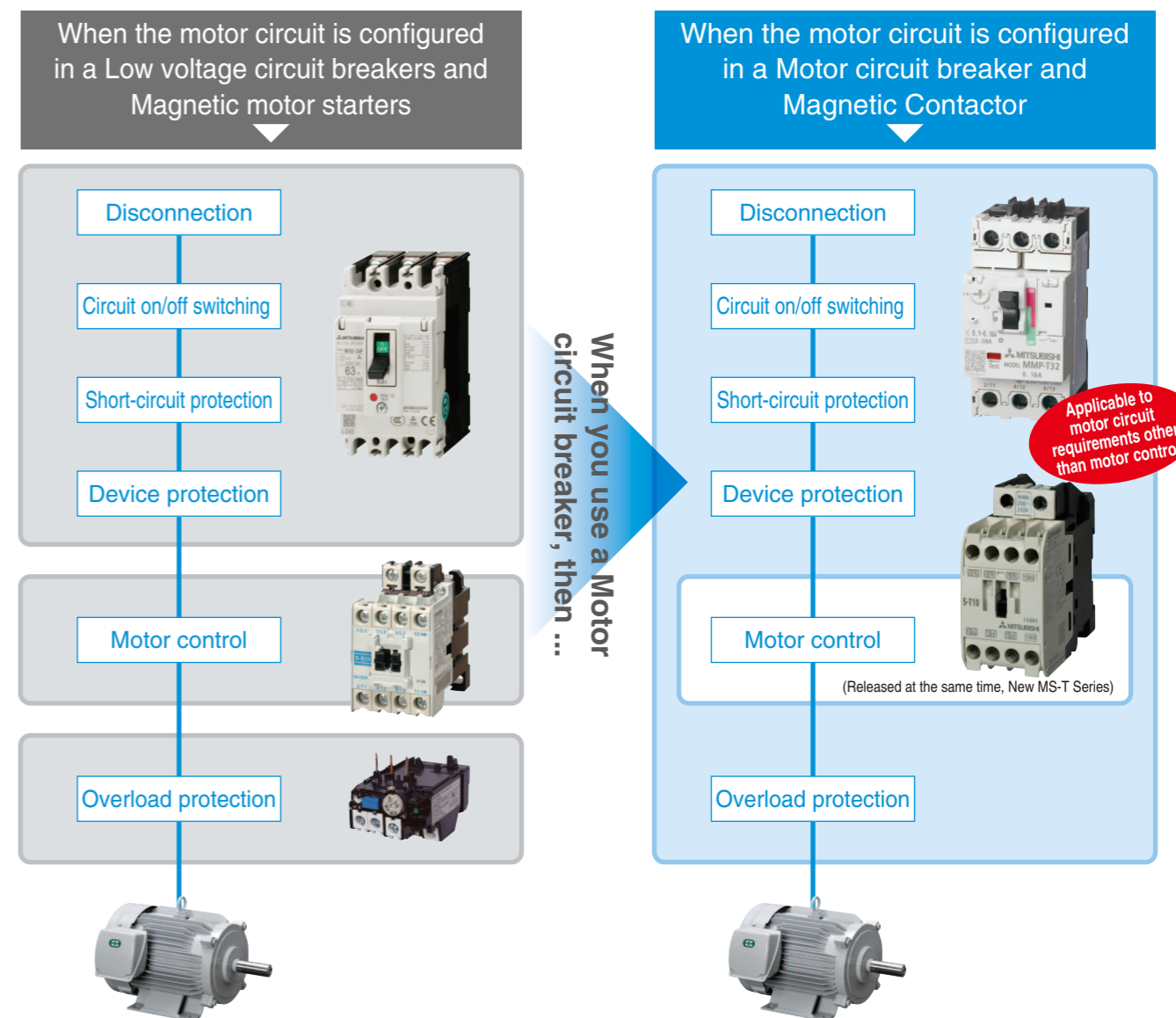

Outline

Advantages of Adopting This Device

Why is a Motor circuit breaker required at this time?

When exporting products to foreign countries including the U.S.A. and European countries, not only the device component but also the motor circuit are required to comply with the standards of the respective countries including UL and EN standards. The electric wires and devices that make up the motor control circuit (Low Voltage Circuit Breakers, Fuse, Magnetic Contactor, Thermal Overload Relays) must be protected under a short-circuit condition. In addition, we need to select each device considering their functions and characteristics. Thus, we have encountered difficulties in realizing the reliable circuit protection at times. The device to reduce such burden is our "Motor circuit breaker". Undertaking multiple protection roles stated above, the Motor circuit breaker can not only protect electric wires and load devices from short-circuit accident but also simplify motor circuit combination. In addition, in North America, a control panel shall be marked with SCCR (short-circuit current rating), but even high SCCR that cannot be covered by the combination of Low voltage circuit breakers and Magnetic motor starters can be covered by the use of a Motor circuit breaker. Having these advantages tends to increase demand for "Motor circuit breakers".

Example In case of application in North America

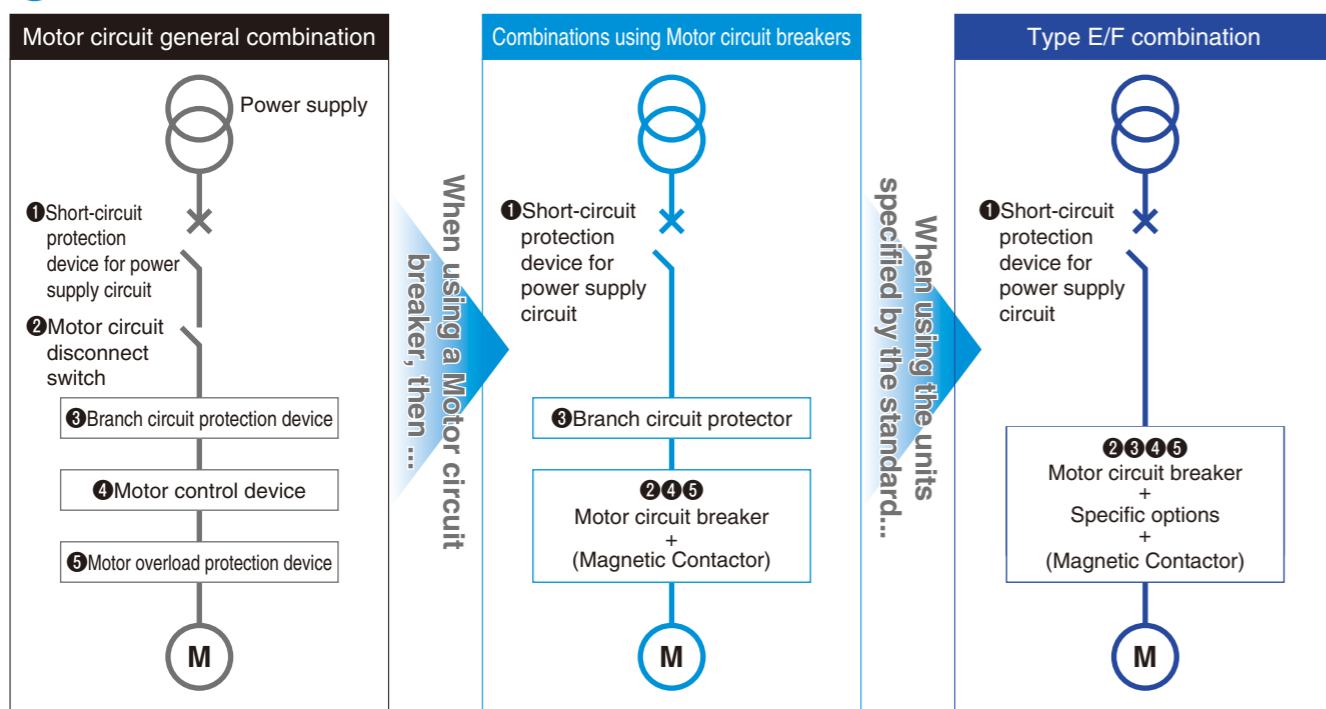

General motor circuits have many devices to be combined and are complicated.

Application of a Motor circuit breaker can integrate the role of ② path disconnection, ④ motor control and ⑤ motor overload protection, to make the circuit simple.

In addition, using the line side terminal adapter kit and short-circuit indicator unit enables the Type E/F*1 circuit combination and also enables ③ branch circuit protection in addition to the protection functions of ②, ④, and ⑤.

In order to connect motor circuit breaker and magnetic contactor, please use the connection conductor unit. *1 MMP-T32LF is not applicable.

Wiring reduction & Space saving

Combination of Motor circuit breaker and option enables wiring reduction and space saving. This allows us to respond to the needs of down-sizing the control panel, which increases the demand for Motor circuit breakers. (For details about wiring reduction & space saving, please refer to the next section.)



Space-saving design has realized down-sizing of the control panel.

Space saving-applied example

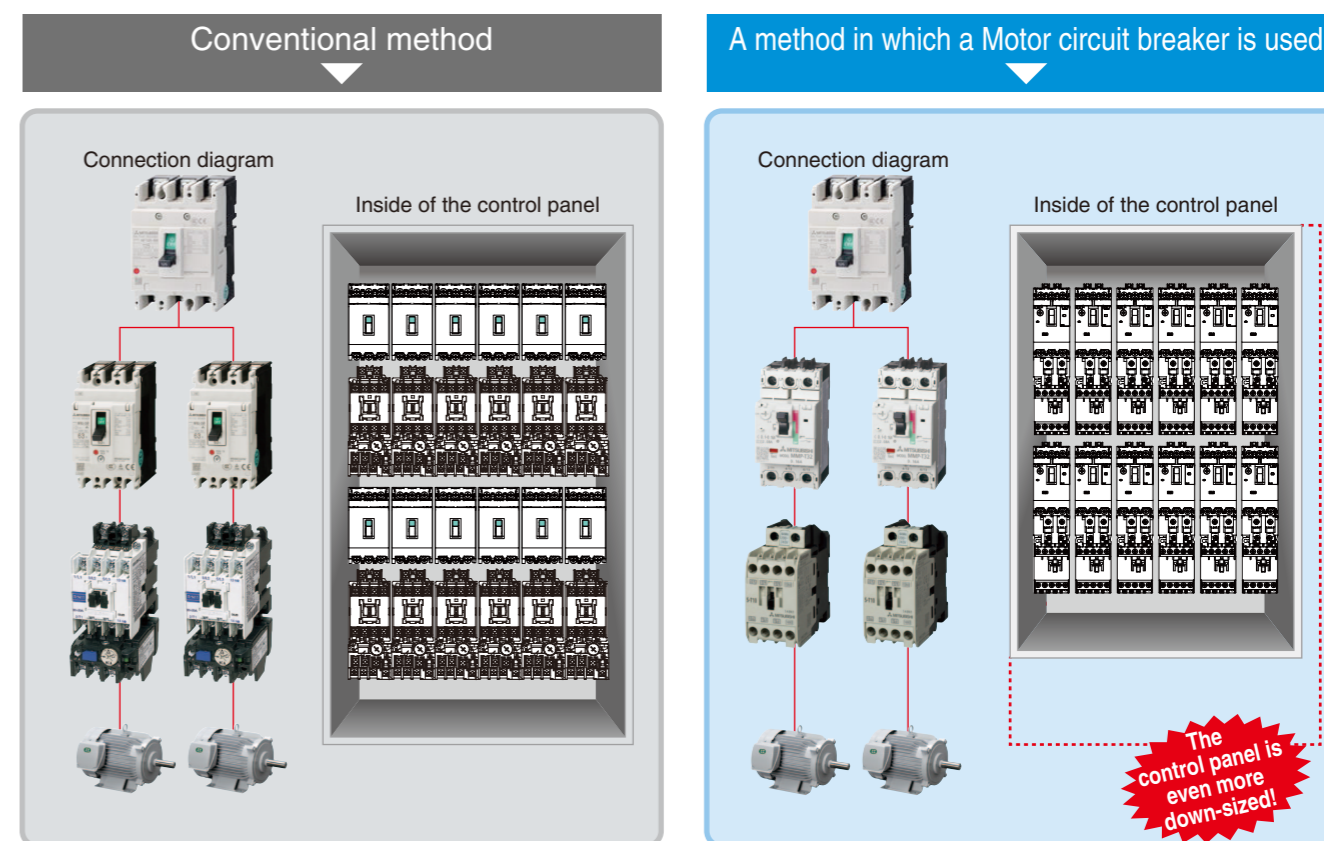

The control panel is even more down-sized!

Advantages of Adopting This Device

S Wiring reduction Smart wiring

Wiring streamlining terminal

MMP-T series

- Using a wiring streamlining terminal facilitates* the wiring!



① Screw holder lifts up the screw ② Insert a round solderless terminal ③ Tighten the screw

* Fast wiring terminals are optional products. (Model name: Add BC to the type designation. E.g.: MMP-T32BC)

Wiring reduction-applied example

MMP-T series

Electric wire-used wiring example

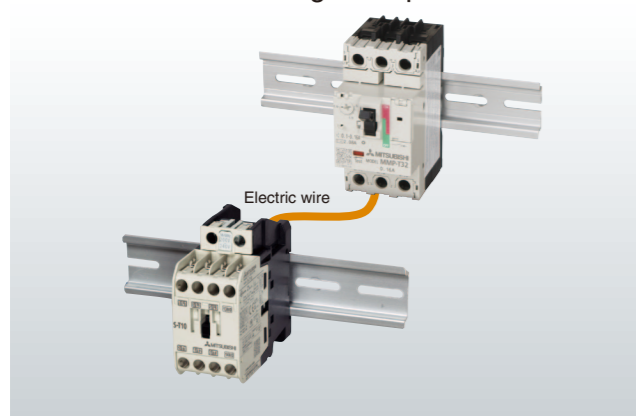

Conductor-joint-unit-used wiring example

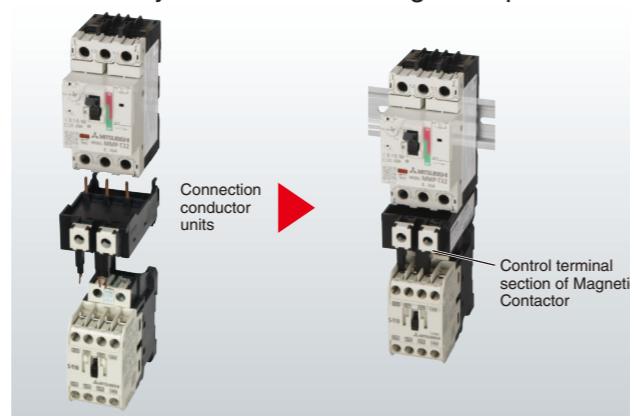

Both common electric wire-used wiring and unit-used wiring are available! Using the unit facilitates combination with respective devices. In addition, the terminal connected to control terminal of magnetic contactor arranged at the front also facilitates the wiring, thus contributing to improvement of production.

S Safety & Quality Safety & Quality

Safe and reliable MMP-T32

MMP-T series

- As with the combination of Low voltage circuit breakers, Magnetic Contactor, and Thermal Overload Relays, the combination of Motor circuit breaker and Magnetic Contactor can prevent secondary disasters.



S Global standard Worldwide coverage

Acquisition of main international standards can support customers' overseas business.

MMP-T series

- Certification to various major international standards

Not only major international standards such as IEC, JIS, UL, CE, and CCC but also other national standards are certified. This will help our customers expand their business in foreign countries. This will help our customers expand their business in foreign countries.

Standards	Applicable standard					Safety certification standard
	International	Japan	European countries		China	
IEC	*1	JIS	EN	Certification body	GB	*1
			EC directive			
			CE			cULus

- UL60947-4-1A Type E/F is also covered.*1

Compliance of the device to UL's Type E/F combination can surely respond to export to the U.S.A. For details, please refer to Page 22.

*1 MMP-T32LF is not applicable.

Specifications

Key points

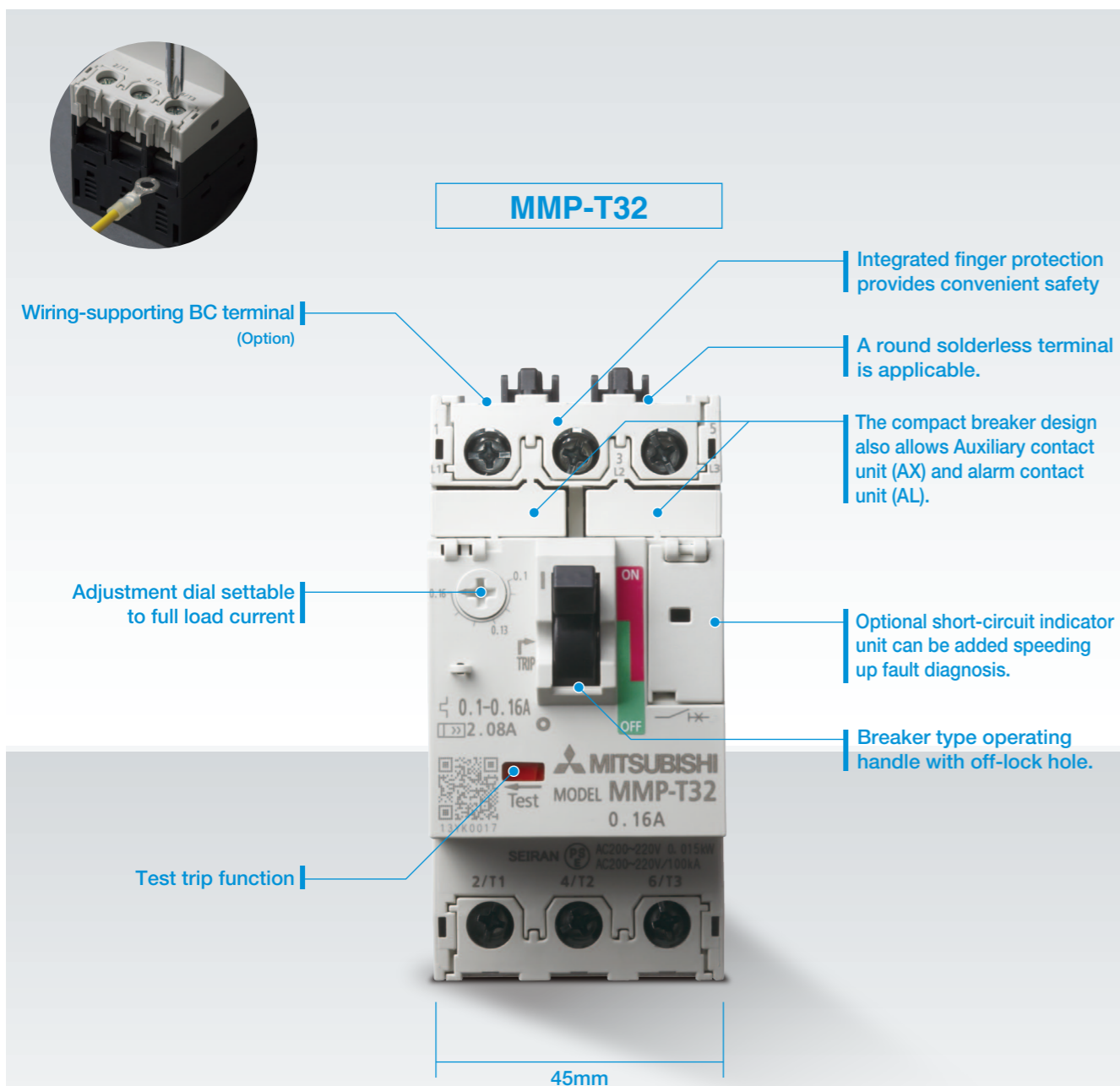

Applicable Standards

- International Standards
 - IEC60947-2, 60947-4-1
 - UL60947-4-1A, CSA C22.2 No.60947-4-1*1
 - TUV approval CE CCC
- Domestic Standards in Japan
 - JIS C8201-2-1 Ann.1, 8201-4-1
 - Electric Applicable Safety Law
 - (Electric articles other than specified) *1

*1 MMP-T32LF is not applicable.

Specification List

Frame A	32													
Type name	NEW MMP-T32LF/MMP-T32BCLF ¹						MMP-T32/MMP-T32BC ¹							
Standard	EN60947-2, EN60947-4-1, IEC60947-2, IEC60947-4-1, GB14048.2						JIS C8201-2-1 Ann.1, JIS 8201-4-1, EN60947-2, EN60947-4-1, IEC60947-2, IEC60947-4-1, GB14048.2, UL60947-4-1A, CSAC22.2NO.60947-4-1							
Number of poles	3													
Handle shape	Tumbler handle													
Rated current I _n [A]	0.1 to 32													
Rated operational voltage U _e [V.]	200 to 690V													
Rated frequency [Hz]	50/60													
Rated insulation voltage U _i [V]	690													
Rated impulse withstand voltage U _{imp} [kV]	6													
Rated short-circuit breaking capacity [kA]	Rated current I _e [A] ²		200/240		400/415		440/460		200/240		400/415		440/460	
	Heater designation	Current setting range	I _{cu}	I _{cs}	I _{cu}	I _{cs}	I _{cu}	I _{cs}	I _{cu}	I _{cs}	I _{cu}	I _{cs}	I _{cu}	I _{cs}
IEC60947-2 ³	0.16	0.1 - 0.16	100	100	100	100	100	100	100	100	100	100	100	100
	0.25	0.16 - 0.25	100	100	100	100	100	100	100	100	100	100	100	100
	0.4	0.25 - 0.4	100	100	100	100	100	100	100	100	100	100	100	100
	0.63	0.4 - 0.63	100	100	100	100	100	100	100	100	100	100	100	100
	1	0.63 - 1	100	100	100	100	100	100	100	100	100	100	100	100
	1.6	1 - 1.6	100	100	100	100	100	100	100	100	100	100	100	100
	2.5	1.6 - 2.5	100	100	100	100	100	100	100	100	100	100	100	100
	4	2.5 - 4	100	100	100	100	100	100	100	100	100	100	100	100
	6.3	4 - 6.3	100	100	100	100	50	50	100	100	100	100	100	100
	8	5.5 - 8	100	100	100	100	15	15	100	100	100	100	50	38
	10	7 - 10	100	100	100	100	15	15	100	100	100	100	50	38
13	9 - 13	100	100	15	7.5	8	4	100	100	100	100	50	38	
18	12 - 18	100	100	15	7.5	8	4	100	100	50	38	35	27	
25	18 - 25	50	50	15	6	6	3	100	100	50	38	35	27	
32	24 - 32	50	50	10	5	6	3	100	100	50	38	35	27	
Selectivity category	JIS C8201-2-1 Ann.1 ³ IEC60947-2						Cat.A							
Utilization category	JIS C8201-4-1 ³ IEC60947-4-1						AC-3							
Trip class (JIS C8201-4-1 ³ , IEC60947-4-1)	10													
Instantaneous release current	13 x Maximum I _e													
Durability	Mechanical [times]		100,000											
	Electrical [times]		100,000											
Phase loss sensitive	Yes													
Trip display	Yes													
Test trip function	Yes													
Auxiliary contact unit	UT-MAX (1a or 1b) ²													
Alarm contact unit	UT-MAL (1a or 1b) ²													
Short-circuit indicator unit	UT-TU													
Weight [g]	330													

*1: MMP-T32BC type is based on the specification of wiring streamlining terminal.

*2: UL-compliant rated working current is described on a different page 26,27.

*3: MMP-T32LF is not applicable.

How to Order

At time of your order, please specify your desired products as shown below. (A space should be inserted in the ▲-marked position.)

Model	Heater nominal
MMP-T32	▲ 32A
MMP-T32BC	
MMP-T32LF	
MMP-T32BCLF	

How to Order the Options

	Type name	Contact arrangement
Auxiliary contact unit	UT-MAX ▲	1a
	UT-MAX ▲	1b
Alarm contact unit	UT-MAL ▲	1a
	UT-MAL ▲	1b
Short-circuit indicator unit	UT-TU	

Specifications

Type 1 Coordination (Non-Reversing/Reversing, Direct Start)

Rated breaking capacities when using MMP-T32 in combination with a magnetic contactor are shown below:

Combining Motor Circuit Breaker MMP-T32 and Magnetic Contactor S(D)-T

AC Three-Phase Motor (AC-3) IEC												Motor Circuit Breakers		
200/240V			400/415V			440/460V			500V			Model Name	Heater Designation	Rated Current Setting Range [A]
P [kW]	I _e [A]	I _q [kA]	P [kW]	I _e [A]	I _q [kA]	P [kW]	I _e [A]	I _q [kA]	P [kW]	I _e [A]	I _q [kA]			
—	—	—	0.2	0.55	50	0.2	0.58	50	0.2	0.5	50	MMP-T32	0.63	0.4 – 0.63
0.1	0.65	50	0.4	1	50	0.4	1	50	0.4	0.8	50		1	0.63 – 1
0.2 0.3	1.1 1.5	50	0.4	1	50	0.4	1	50	0.75	1.4	50		1.6	1 – 1.6
0.4	2	50	0.75	1.7	50	0.75	1.7	50	1.5	2.5	50		2.5	1.6 – 2.5
0.75	3.3	50	1.5	3.1	50	1.5	3	50	2.2	3.6	50		4	2.5 – 4
1.5	6	50	2.2	4.5	50	2.2	4.2	50	3.7	5.7	50		6.3	4 – 6.3
1.5	6	50	3.7	7.1	50	3.7	6.5	50	3.7	5.7	42		8	5.5 – 8
2.2	8.6	50	3.7	7.1	50	5.5	9.8	50	5.5	8.4	42		10	7 – 10
—	—	—	5.5	10.5	50	5.5	9.8	50	7.5	11.2	42		13	9 – 13
3.7	13.4	50	7.5	14	50	7.5	12.7	35	11	16.4	10		18	12 – 18
5.5	19.8	50	11	20.5	50	11	18.5	35	—	—	—		25	18 – 25
7.5	26.4	50	15	27	50	15	24.5	35	—	—	—		32	24 – 32

Note 1. Unit model names of motor circuit breakers and magnetic contactors to be combined are as follows:

S-T10–T20: UT-MT20, S-T32: UT-MT32

SD-T12/T20: UT-MT20D + UT-BT32D, SD-T32: UT-MT32D + UT-BT32D

S-2XT10: UT-MT20 + UT-RT10 + UT-BT20 (2 Units), S-2XT12/T20: UT-MT20 + UT-RT20 + UT-BT20 (2 Units),

S-2 × T32: UT-MT32 + UT-RT32 + UT-BT32 (2 Units)

SD-2 × T12/T20: UT-MT20D + UT-RT20 + UT-BT32D (2 Units), SD-2 × T32: UT-MT32D + UT-RT32 + UT-BT32D (2 Units)

S-T21/T25/SD-T21/S-2 × T21/SD-2 × T21/T25: Electric Wire Connection

Note 2. The above table shows those selected based on Mitsubishi standard 3-phase 4-pole motor SF-JR.

Combining Motor Circuit Breaker MMP-T32 and Magnetic Contactor SD-Q

AC Three-Phase Motor (AC-3) IEC												Motor Circuit Breakers		
200/240V			400/415V			440/460V			500V			Model Name	Heater Designation	Rated Current Setting Range [A]
P [kW]	I _e [A]	I _q [kA]	P [kW]	I _e [A]	I _q [kA]	P [kW]	I _e [A]	I _q [kA]	P [kW]	I _e [A]	I _q [kA]			
—	—	—	0.2	0.55	50	0.2	0.58	50	0.2	0.5	50	MMP-T32(BC)	0.63	0.4 – 0.63
0.1	0.65	50	0.4	1	50	0.4	1	50	0.4	0.8	50		1	0.63 – 1
0.2 0.3	1.1 1.5	50	0.4	1	50	0.4	1	50	0.75	1.4	50		1.6	1 – 1.6
0.4	2	50	0.75	1.7	50	0.75	1.7	50	1.5	2.5	50		2.5	1.6 – 2.5
0.75	3.3	50	1.5	3.1	50	1.5	3	50	2.2	3.6	50		4	2.5 – 4
1.5	6	50	2.2	4.5	50	2.2	4.2	50	3.7	5.7	50		6.3	4 – 6.3
1.5	6	50	3.7	7.1	50	3.7	6.5	50	3.7	5.7	42		8	5.5 – 8
2.2	8.6	50	3.7	7.1	50	—	—	—	—	—	—		10	7 – 10

Note. The above table shows those selected based on Mitsubishi standard 3-phase 4-pole motor SF-JR.

Magnetic Contactors (Non-Reversing/Reversing)															Various Units			
Model Name															Model Name			
200/240V			400/415V			440/460V			500V									
S-(2X)T10(BC)	S(D)-(2X)T12(BC)	S(D)-(2X)T20(BC)	S(D)-(2X)T21(BC)	S-(2X)T25(BC)	S(D)-(2X)T32(BC)	S-(2X)T10(BC)	S(D)-(2X)T12(BC)	S(D)-(2X)T20(BC)	S(D)-(2X)T21(BC)	S-(2X)T25(BC)	S(D)-(2X)T32(BC)	S-(2X)T10(BC)	S(D)-(2X)T12(BC)	S(D)-(2X)T20(BC)	S(D)-(2X)T21(BC)	S-(2X)T25(BC)	S(D)-(2X)T32(BC)	Note 1

Magnetic Contactors (Non-Reversing/Reversing)		Connecting Conductor Unit
Model Name		Model Name
SD-Q(R)11	SD-Q(R)12	UT-MQ12

Specifications

Working Environment

- (1) Ambient Temperature : -10°C ~ 40°C
(applied outside control panel) Daily Average Temperature of Maximum 35°C, Yearly Average Temperature of Maximum 25°C
- (2) Maximum Temperature Inside Control Panel: 55°C (yearly average temperature inside panel of 40°C or below)
Please note that operation characteristics are affected by the ambient temperature.
- (3) Relative Humidity : 45% ~ 85% RH (no condensation, no freezing)
- (4) Altitude : 2,000 m or below
- (5) Vibration : 10 ~ 55 Hz; 19.6 m/s² or less
- (6) Shock : 49 m/s² or less
- (7) Atmosphere : Low levels of dust, smoke, corrosive gas, moisture or sodium.
When used in a sealed state for a long time, contact failure, etc., can occur.
Do not use the products in an atmosphere containing flammable gas.
- (8) Storage Temperature/ Relative Humidity : -30°C ~ 65°C/45% ~ 85%RH (no condensation, no freezing) Storage temperature refers to ambient temperature during transportation or storage of product. When starting use of the product, the temperature must be within the working temperature.
- (9) Precautions for Use : Set the position of the adjusting dial in consideration of the ambient temperature and the mounting conditions.

Operating Current Setting

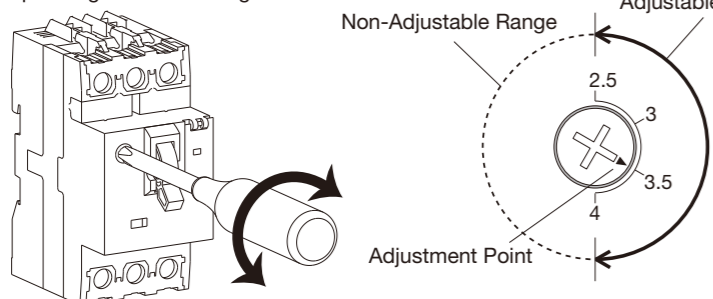

<Fig. 1. Ambient temperature compensation properties>

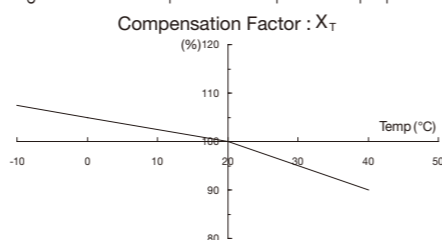

<Fig. 2. Mounting condition compensation>

	[Non-Close Mounting] $X_{SET} = X_T$
	[Close Mounting] $X_{SET} = X_T - 5$

$$I_{SET} = I/X_{SET} \times 100$$

- I : Motor Rated Current
- X_{SET} : Determined based on the following Figures 1 and 2

E.g.: If I = 2.8 A, Ambient Temperature = 40°C, and close mounted
 $I_{SET} = 2.8/(90-5) \times 100 \approx 3.3 \text{ A} \rightarrow$ Set the adjusting dial to position 3.3 A.

(10) Connecting

Model Name	MMP-T32	UT-MAX(LL), UT-MAL(LL)
Terminal Screw Size	M4	M3.5
Recommended Length L of Insulation Layer to be Peeled off When Wired with Bare Wire	10mm	8.5mm
Applicable Wire Size	Single Wire [mm]	φ 1.6, φ 2.6
	Stranded Wire [mm ²]	1 - 6
	UL Electrical Wire (60/70°C, Copper Only)	#14 - #8
Crimp Lug Size	R1.25-4 - 8-4NS	0.5-3.7A - 2-S3A
Terminal Screw Tightening Torque [N·m]	1.7	1.0

* For details about handling, temperature compensation, close mounting, etc., refer to the Operating Manual.

(11) Application to Single-Phase Motors

Select an appropriate heater designation upon confirmation of the full-load current.
 As Motor Circuit Breakers have an open-phase protection function, single-phase motors should be connected as in the figure at right.

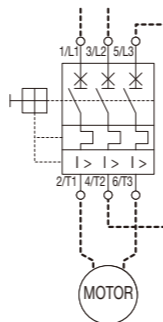

Operating Characteristic Curve

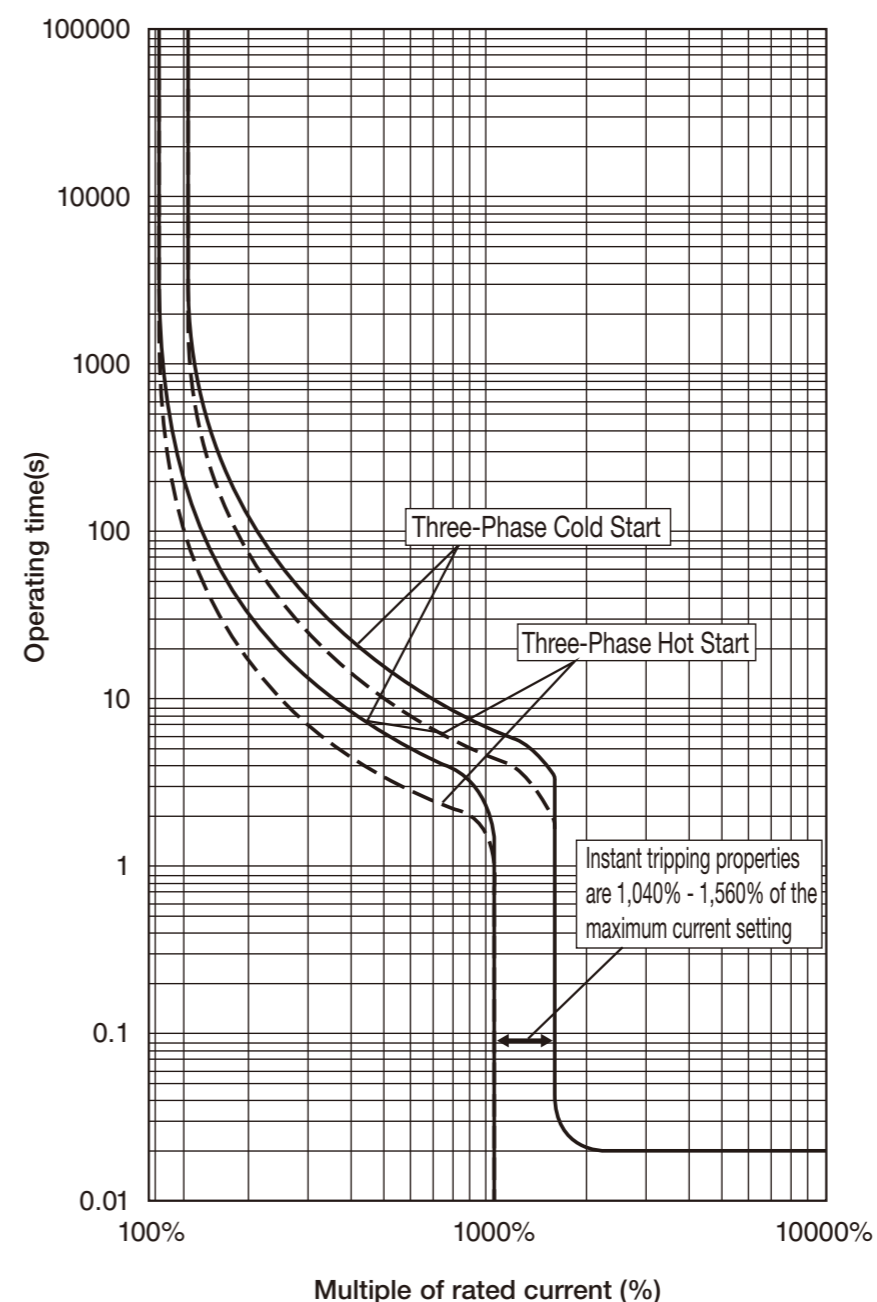

Optional Unit

List of Options

Number	Product name	Model	Specification	Description	Applied model
①	Auxiliary contact unit (to be internally installed)	UT-MAX	1a	The contacts of this unit operate in unison with the turning ON/OFF of the main unit.	MMP-T32 (BC)(LF)
		UT-MAXLL (for subtle load)	1a		
②	Alarm contact unit (to be internally installed)	UT-MAL	1a	The contacts of this unit operate (either short-circuits, overloads, open-phase) in unison with the trip operation of the main unit.	
		UT-MALLL (for subtle load)	1a		
③	3 phase feed-in terminal	UT-EP3		This is a terminal block unit that can enable the wiring of bare wires (single core wire/stranded wire) on the power supply side if the unit is connected in parallel with a bus bar.	
④	Bus bar	UT-2B4	45mm Clearance Row of 2	A unit that can supply power (parallel connection) to 2 or 3 units individually without use of electric wire.	
		UT-3B4	45mm Clearance Row of 3		
		UT-2B5	57mm Clearance Row of 2		
		UT-3B5	57mm Clearance Row of 3		
⑤	Line side terminal adapter	UT-CV3		Power supply-side terminal cover to respond to UL60947-4-1A, Type E/F. This kit consists of terminal adapter, terminal cover and 3 screws.	
⑥	Short-circuit indicator unit	UT-TU		This unit has a feature that the red indication is lit only when the device is tripped due to short-circuit. This unit is required for application to UL60947-4-1A, Type E/F.	
⑦	Connection conductor unit	UT-MT20		A unit to connect and link the MMP-T32 and Magnetic Contactor electrically and mechanically. Necessary for application to UL60947-4-1A, Type F	
		UT-MT32			
		UT-MQ12			
		UT-MT20D			
⑧	Mounting base unit	UT-BT20		A plate to install the combination starter with MMP-T32 and Magnetic Contactor combined. Rail mounting and screw mounting are available.	
		UT-BT32			
		UT-BT32D			
⑨	Joining block unit	UT-RT10		A set of the blocks for mechanically connecting two mounting base units. Necessary for combination of MMP-T32 with reversible magnetic contactor	
		UT-RT20			
		UT-RT32			

For combination model names, please refer to the outline drawings on page 19.

Option combination Diagram

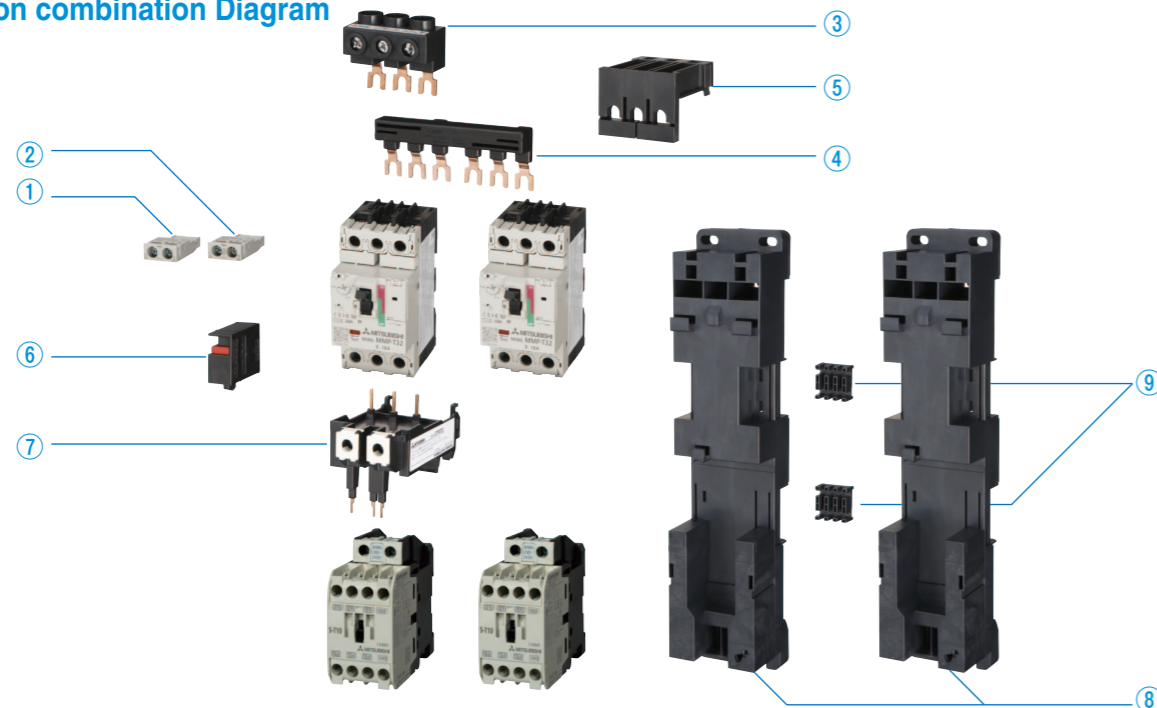

Specifications

Operating Optional Units

Unit Types	Model Name	Contact Arrangement	Operation of MMP-T32			
			ON	Short Circuit Tripping	Overload/Open-Phase Tripping	OFF
Auxiliary Contact Unit	UT-MAX(LL)	1a	ON	OFF	OFF	OFF
		1b	OFF	ON	ON	ON
Alarm Contact Unit	UT-MAL(LL)	1a	OFF	ON	ON	OFF
		1b	ON	OFF	OFF	ON
Short-circuit Display Unit	UT-TU	—	No Display	Red Display	No Display	No Display

Specifications of Auxiliary Contact Unit and Alarm Contact Unit

Model Name	Contact Arrangement	Rated Insulation Voltage	Durability		Minimum Applicable Load	Rated Current [A]					
			Mechanical	Electrical		AC-12		DC-12			
						125V	250V	30V	48V	125V	250V
UT-MAX	1a, 1b	250V	0.1 mil. times	10,000 times	5 V/160 mA 24 V/40 mA	5	3	—	—	0.4	0.2
UT-MAL	1a, 1b		1,000 times	1,000 times							
UT-MAXLL	1a, 1b	125V	0.1 mil. times	10,000 times	5 V/1 mA 24 V/0.25 mA	0.1	—	0.1	0.03	—	—
UT-MALLL	1a, 1b		1,000 times	1,000 times							

Specifications of Power Supply Block and Bus Bar

Model Name	Conventional Free Air Thermal Current Ith [A]	Rated Conditional Short-Circuit Current Iq [kA]	Applicable Electrical Wire
UT-EP3	63	50	Flexible Stranded Wire: 1 × 6...25 mm ² Stranded Wire : 1 × 6...16 mm ² (Cannot be wired with crimp lug)
UT-2B4/3B4/2B5/3B5			1 × R1.25/4...8-4NS (Cannot be wired with bare wire)

Parallel Connection Using Bus Bar Unit

- When connecting more than four MMP-T32 Motor Circuit Breakers in parallel, connect them alternately reversing multiple UT-□ B □ Bus Bar Units.
- Meet the following requirement in limiting the number of units when connecting in parallel. [Rated Current of Bus Bar Unit (63 A)] > [Sum Value of Settling Current (Parallel Connection)]

Application Example: For Connecting 4 Units in Parallel (Close Mounting)

Bus Bar Units to be Used

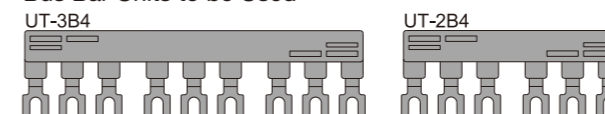

Connection Example * Determine the arrangement of the bus bar unit according to the feed position.

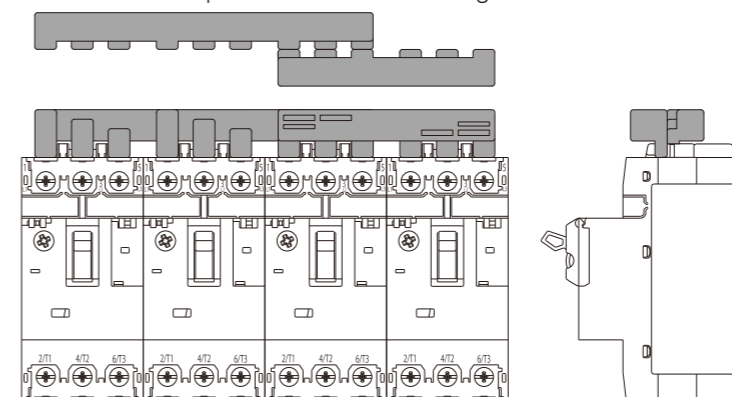

Outline Drawing

MMP-T32

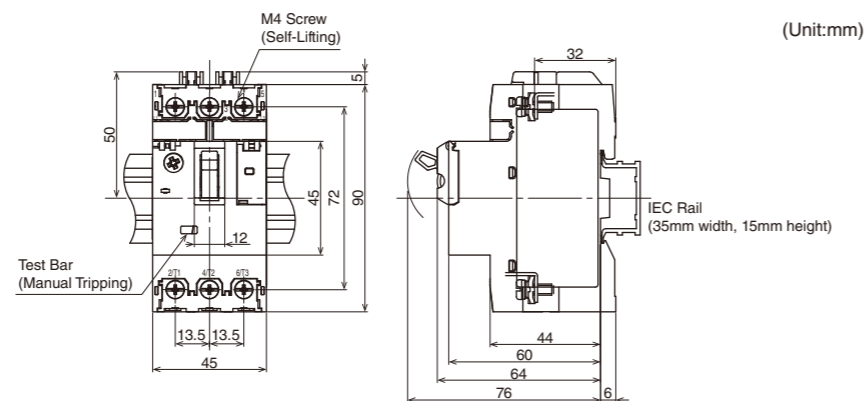

MMP-T32 + UT-MT20 + S-T10

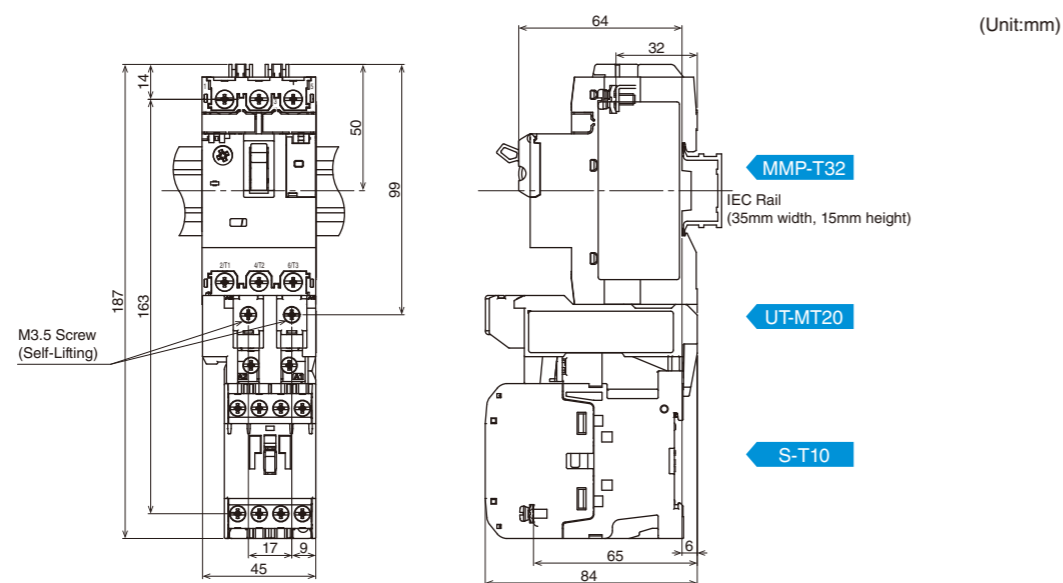

MMP-T32 + UT-MT20 + S-T12/T20

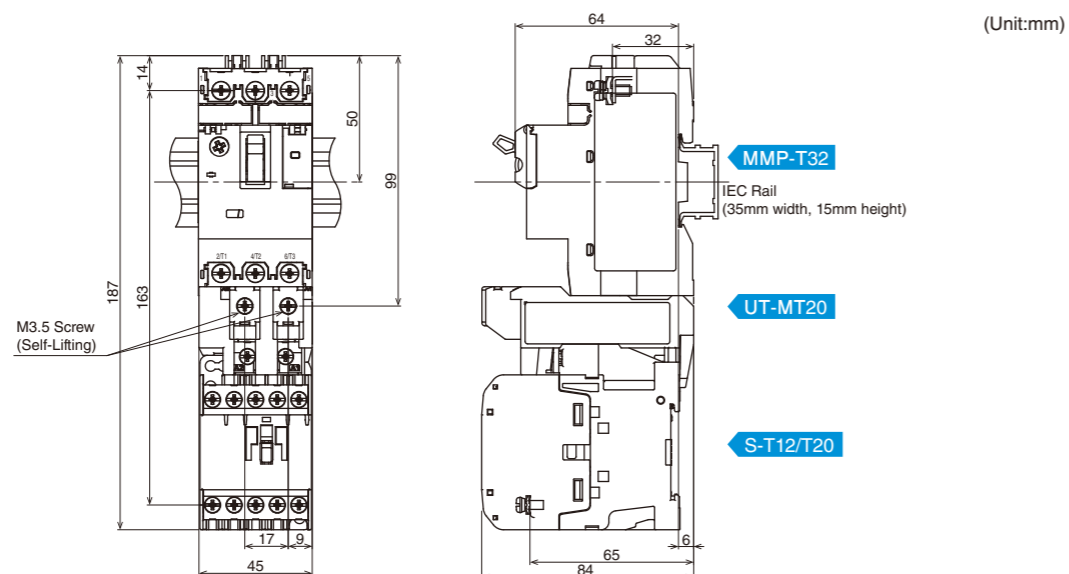

MMP-T32 + UT-MT32 + S-T32

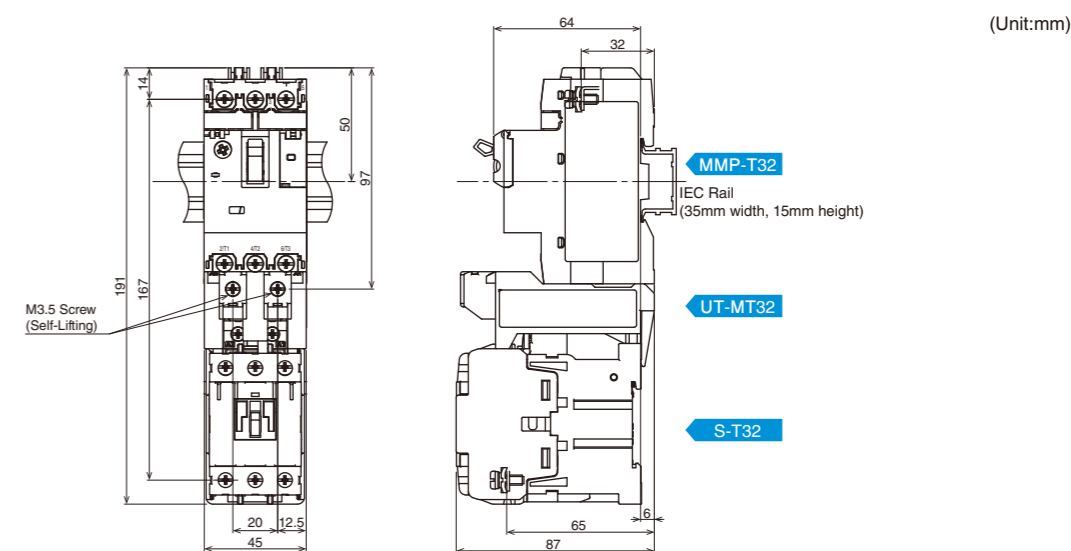

Model Name
UT-MT32
S-T32

MMP-T32 + UT-MT20D + SD-T12/T20 + UT-BT32D

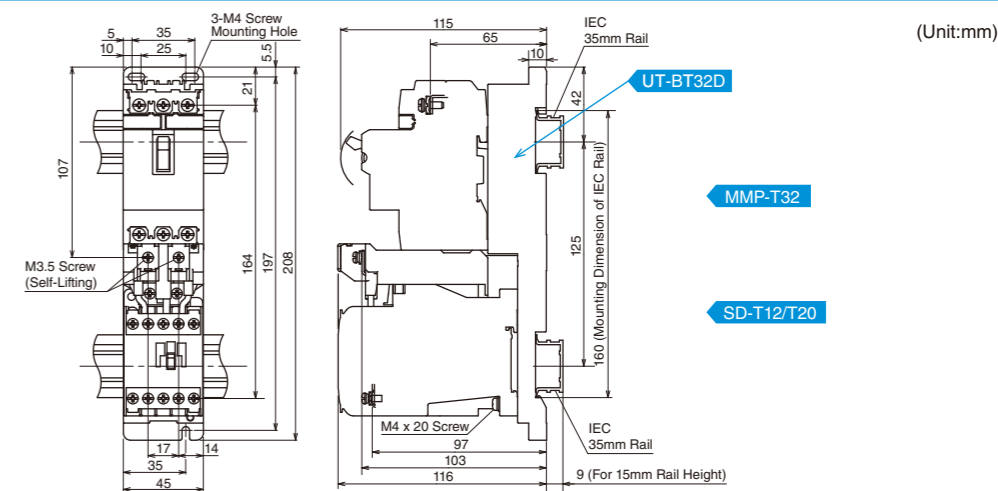

Model Name
UT-MT20D
UT-BT32D
SD-T12
SD-T20

MMP-T32 + UT-MT32D + SD-T32 + UT-BT32D

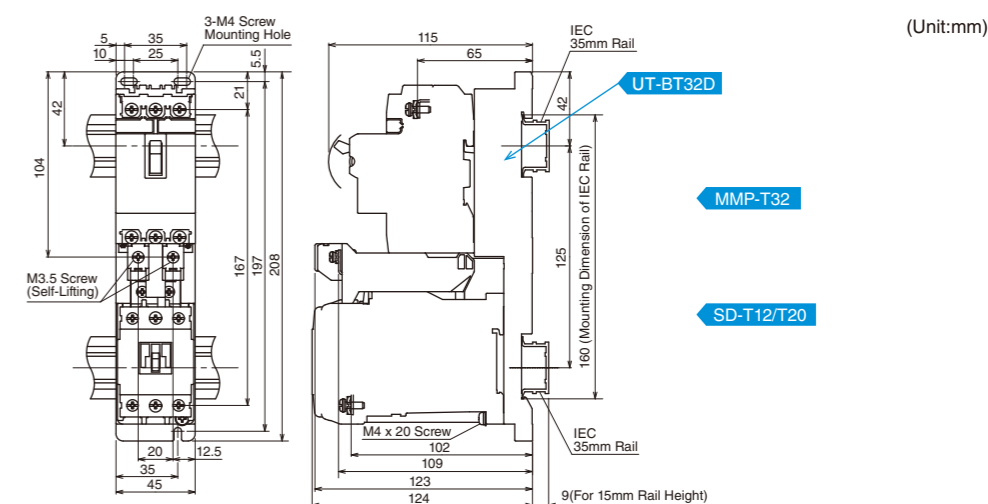

Model Name
UT-MT32D
SD-T32

Outline Drawing

MMP-T32 + UT-MAX(LL)/UT-MAL(LL)

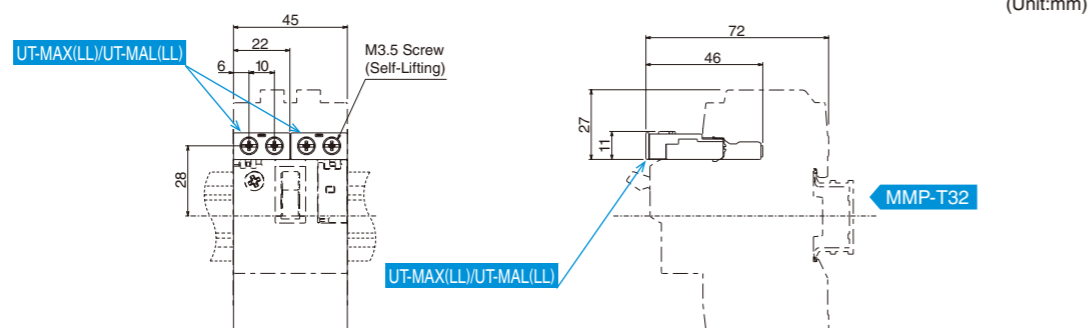

(Unit:mm)

Model Name
UT-MAX
UT-MAXLL
UT-MAL
UT-MALLL

* The above figure shows the state where 2 units [UT-MAX(LL) and/or UT-MAL(LL)] are installed.
External dimensions of UT-MAX(LL) and UT-MAL(LL) are equivalent.

MMP-T32x3 + UT-3B4/UT-3B5

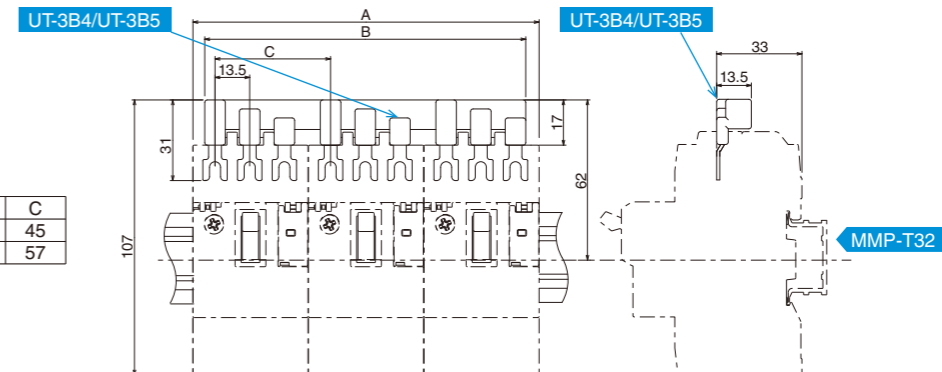

(Unit:mm)

Dimension	A	B	C
UT-3B4	135	125	45
UT-3B5	159	149	57

Model Name
UT-3B4
UT-3B5

MMP-T32 + UT-CV3 + UT-TU

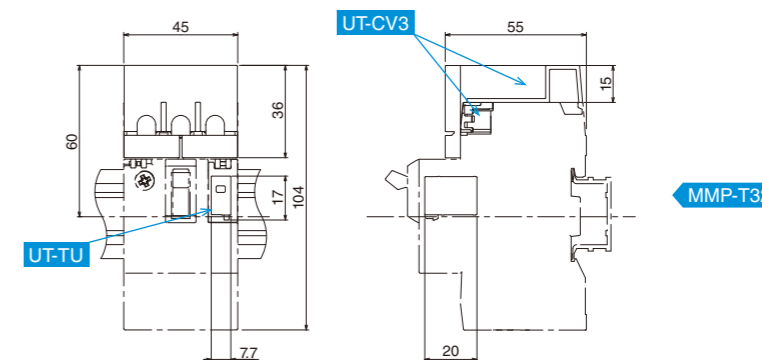

(Unit:mm)

Model Name
UT-CV3
UT-TU

MMP-T32x2 + UT-EP3 + UT-B□

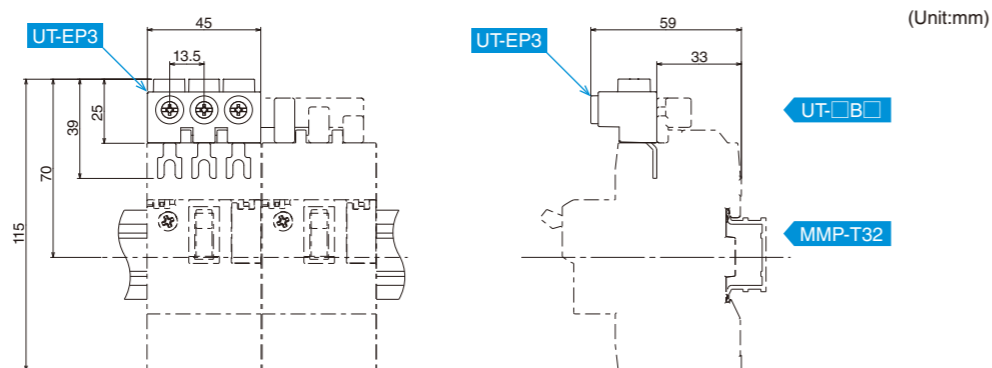

(Unit:mm)

Model Name
UT-EP3

MMP-T32x2 + UT-2B4/UT-2B5

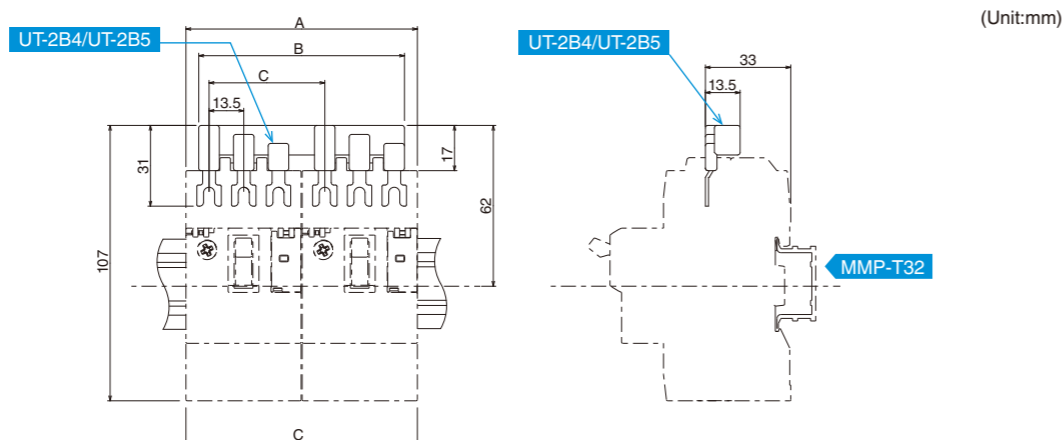

(Unit:mm)

Dimension	A	B	C
UT-2B4	90	80	45
UT-2B5	120	92	57

Model Name
UT-2B4
UT-2B5

MMP-T32 + UT-MT□ + UT-BT□ + S-T□

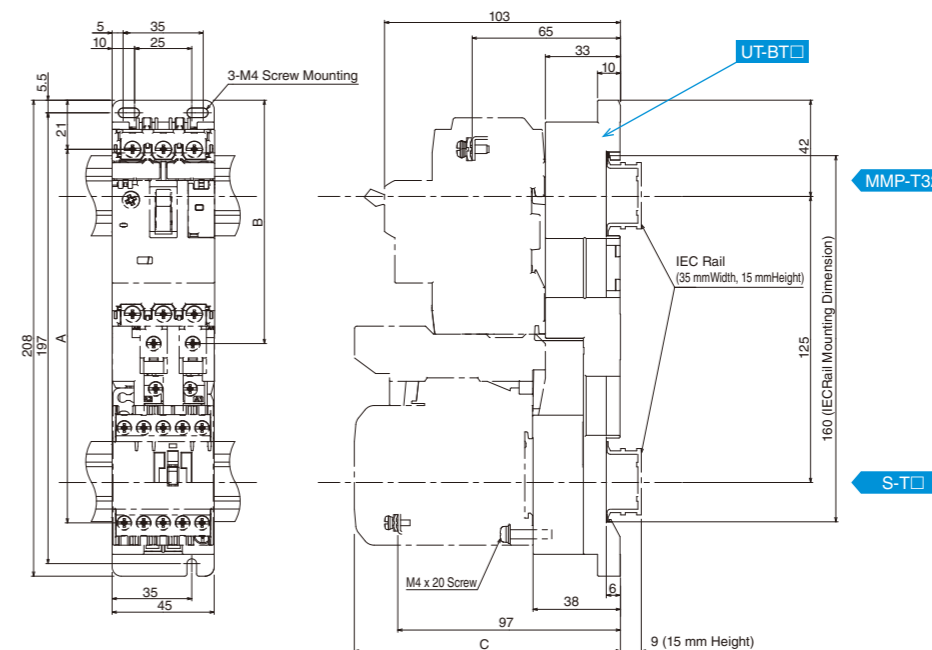

(Unit:mm)

Dimension	A	B	C	Combination Contactor	Combination Connecting Conductor Unit
UT-BT20	163	106	116	S-T10/T12/T20	UT-MT20
UT-BT32	167	104	120	S-T32	UT-MT32

Model Name
UT-BT20
UT-BT32

Outline Drawing

List of Combination Models

MMP-T32 + UT-MT□ + UT-BT□ + S-2×T□ + UT-RT□ + UT-SD□

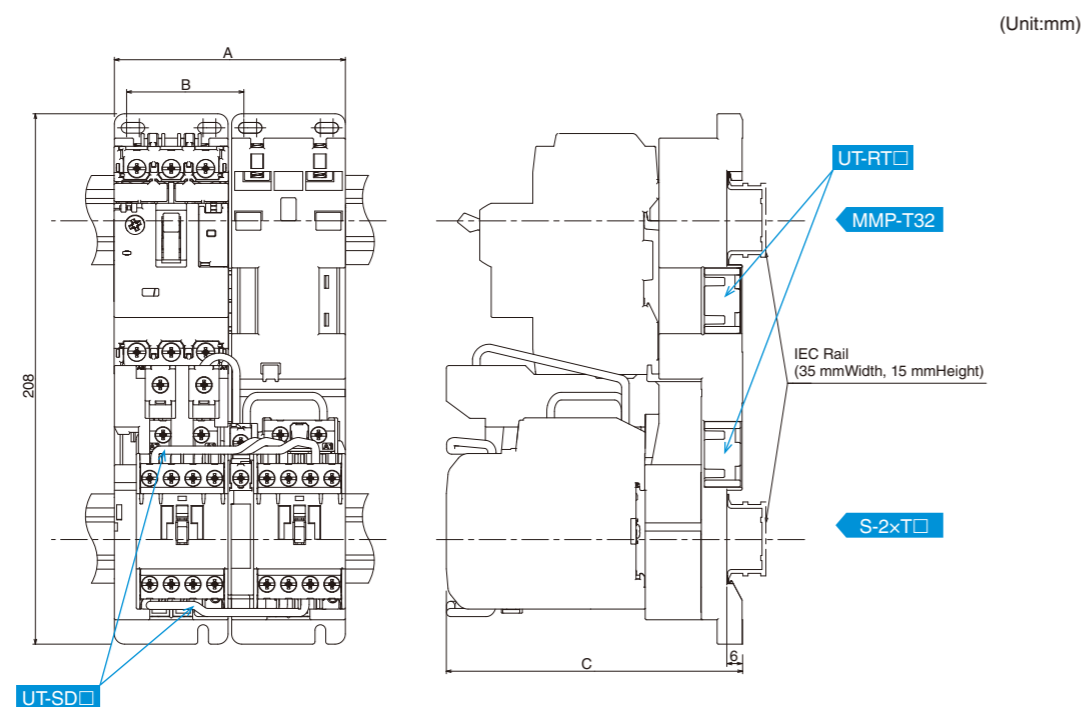

Dimension	A	B	C	Combination Contactor	Combination Connecting Conductor Unit	Combination Mounting Base Unit
UT-RT10	91	46	116	S-2 × T10	UT-MT20	UT-BT20
				SD-2 × T10	UT-MT20D	UT-BT32D
UT-RT20	99	54	116	S-2 × T12/T20	UT-MT20	UT-BT20
				SD-2 × T12/T20	UT-MT20D	UT-BT32D
UT-RT32	98	53	150	S-2 × T32	UT-MT32	UT-BT32
				SD-2 × T32	UT-MT32D	UT-BT32D

Model Name
UT-RT10
UT-RT20
UT-RT32

MMP-T32 + UT-MQ12 + SD-Q□

(Unit:mm)

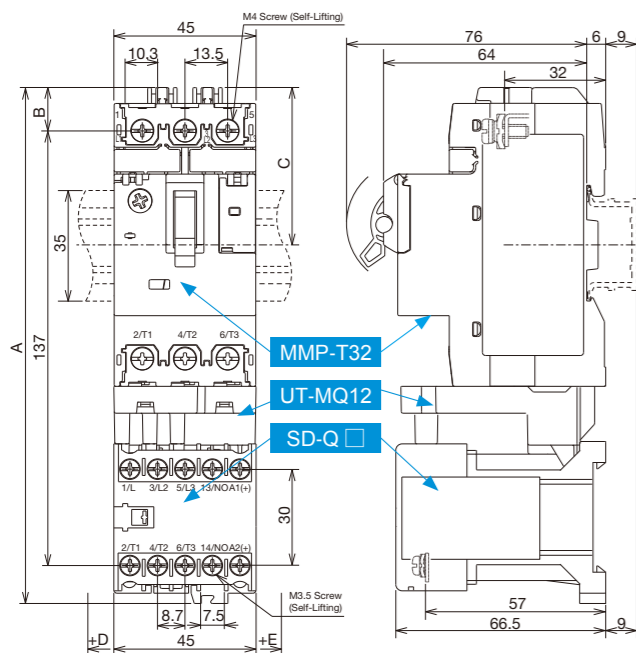

Dimension					Combination Contactor	Combination Connecting Conductor Unit
A	B	C	D	E		
163	14	50	0	0	SD-Q11	UT-MQ12
163	14	50	9.5	0	SD-Q12	
166	14	50	0	45	SD-QR11	
166	14	50	9.5	54.5	SD-QR12	

Model Name
UT-MQ12
SD-Q11
SD-Q12
SD-QR11
SD-QR12

Motor Circuit Breaker (Type E Optional Unit)	Magnetic Contactor	Connecting Conductor Unit	Mounting Base Unit	Mounting Method	Joining Block Unit	
MMP-T32 (UT-CV3, UT-TU)	S-T10	Non-Reversing	UT-MT20	Configurable without the base unit if screw mounting is not required	DIN Rail (1 pc)	—
	S-T12/T20		UT-MT20		DIN Rail (1 pc)	—
	S-T32		UT-MT32		DIN Rail (1 pc)	—
	S-T10		UT-MT20	UT-BT20	Screw Mounting or DIN Rail (2 pcs)	—
	S-T12/T20		UT-MT20	UT-BT20	Screw Mounting or DIN Rail (2 pcs)	—
	S-T32		UT-MT32	UT-BT32	Screw Mounting or DIN Rail (2 pcs)	—
	S-2XT10	Reversing	UT-MT20	UT-BT20 (2 Units)	Screw Mounting or DIN Rail (2 pcs)	UT-RT10
	S-2XT12/T20		UT-MT20	UT-BT20 (2 Units)	Screw Mounting or DIN Rail (2 pcs)	UT-RT20
	S-2XT32		UT-MT32	UT-BT32 (2 Units)	Screw Mounting or DIN Rail (2 pcs)	UT-RT32
	SD-Q11/Q12	Non-Reversing	UT-MQ12	No Applicable Base Unit Available (Screw Mounting Not Possible)	DIN Rail (1 pc)	—
	SD-QR11/QR12	Reversing	UT-MQ12		DIN Rail (1 pc)	Not Required
	SD-T12/T20	Non-Reversing	UT-MT20D	UT-BT32D	Screw Mounting or DIN Rail (2 pcs)	—
	SD-T32		UT-MT32D	UT-BT32D	Screw Mounting or DIN Rail (2 pcs)	—
	SD-2XT12/T20	Reversing	UT-MT20D	UT-BT32D (2 Units)	Screw Mounting or DIN Rail (2 pcs)	UT-RT20
	SD-2XT32		UT-MT32D	UT-BT32D (2 Units)	Screw Mounting or DIN Rail (2 pcs)	UT-RT32

UL Standard and SCCR

Basic Circuit Configurations Provided by NEC (National Electric Code) and Motor Circuit Breaker Applications

Section 430 of the NEC (National Electric Code) requires that the basic circuit configuration of the electric motor protection circuit should be as shown in the diagram below.

Mitsubishi Motor Circuit Breakers feature: (2) disconnection; (4) motor control; and (5) overload protection — all with one unit. It is certified as Type E in combination with a specific optional unit, as well as Type F in combination with a magnetic contactor; and is also applicable for (3) branch circuit protection in addition to (2), (4), and (5).

Mitsubishi Motor Circuit Breakers allow you to reduce the quantity of equipment required to meet the basic circuit configuration for the motor protection circuit provided by the NEC and to improve SCCR.

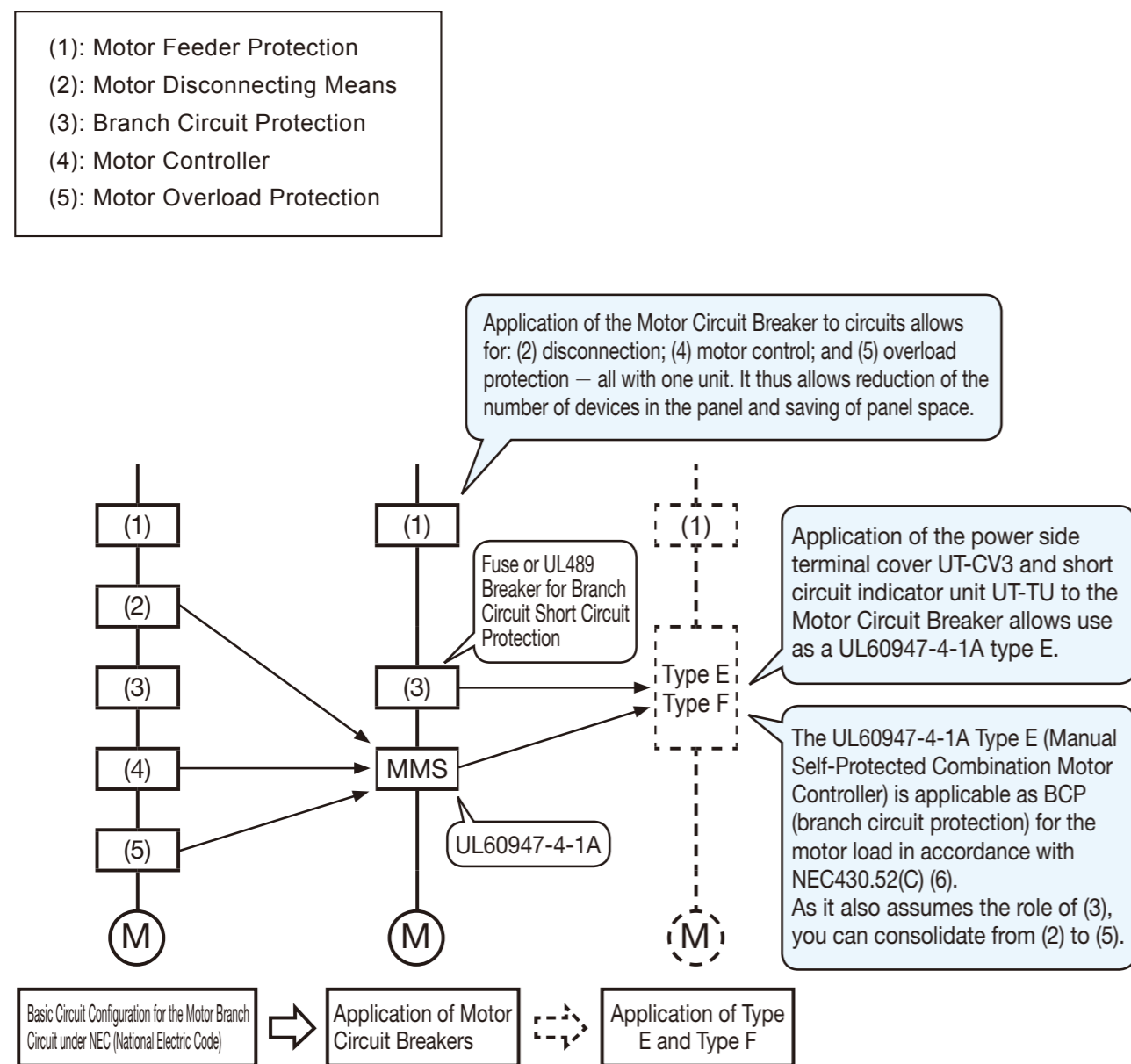

Motor Circuit Breaker Rating

[Certified Rating]

◆ Main Circuit Single Phase

Motor Circuit Breakers (Current Setting Range)	Certified Rating												
	110-120V		200V		208V		220-240V		440-480V		550-600V		
	Maximum Rated Capacity [HP]	Maximum Rated Operating Current [A]	Maximum Rated Capacity [HP]	Maximum Rated Operating Current [A]	Maximum Rated Capacity [HP]	Maximum Rated Operating Current [A]	Maximum Rated Capacity [HP]	Maximum Rated Operating Current [A]	Maximum Rated Capacity [HP]	Maximum Rated Operating Current [A]	Maximum Rated Capacity [HP]	Maximum Rated Operating Current [A]	
MMP-T32	0.1 – 0.16	—	0.16	—	0.16	—	0.16	—	0.16	—	0.16	—	0.16
	0.16 – 0.25	—	0.25	—	0.25	—	0.25	—	0.25	—	0.25	—	0.25
	0.25 – 0.4	—	0.4	—	0.4	—	0.4	—	0.4	—	0.4	—	0.4
	0.4 – 0.63	—	0.63	—	0.63	—	0.63	—	0.63	—	0.63	—	0.63
	0.63 – 1	—	1	—	1	—	1	—	1	—	1	—	1
	1 – 1.6	—	1.6	—	1.6	—	1.6	1/10	1.5	—	1.6	—	1.6
	1.6 – 2.5	—	2.5	1/6	2.5	1/6	2.4	1/6	2.2	1/2	2.5	1/2	2
	2.5 – 4	1/8	3	1/3	4	1/3	4	1/3	3.6	1	4	1-1/2	4
	4 – 6.3	1/4	5.8	1/2	5.6	1/2	5.4	1/2	4.9	2	6	2	4.8
	5.5 – 8	1/3	7.2	3/4	7.9	3/4	7.6	1	8	2	6	3	6.8
	7 – 10	1/2	9.8	1	9.2	1	8.8	1-1/2	10	3	8.5	—	10
	9 – 13	3/4	13	1-1/2	11.5	1-1/2	11	2	12	5	13	5	11.2
	12 – 18	1	16	2	13.8	2	13.2	3	17	5	14	7-1/2	16
18 – 25	2	24	3	19.6	3	18.7	—	25	7-1/2	21	10	20	
24 – 32	2	24	5	32	5	30.8	5	28	10	26	15	27	

Note 1. Since " — " has no horsepower setting by standard, select the maximum rated operating current [A].

◆ Main Circuit Three Phase

Motor Circuit Breakers (Current Setting Range)	Certified Rating												
	110-120V		200V		208V		220-240V		440-480V		550-600V		
	Maximum Rated Capacity [HP]	Maximum Rated Operating Current [A]	Maximum Rated Capacity [HP]	Maximum Rated Operating Current [A]	Maximum Rated Capacity [HP]	Maximum Rated Operating Current [A]	Maximum Rated Capacity [HP]	Maximum Rated Operating Current [A]	Maximum Rated Capacity [HP]	Maximum Rated Operating Current [A]	Maximum Rated Capacity [HP]	Maximum Rated Operating Current [A]	
MMP-T32	0.1 – 0.16	—	0.16	—	0.16	—	0.16	—	0.16	—	0.16	—	0.16
	0.16 – 0.25	—	0.25	—	0.25	—	0.25	—	0.25	—	0.25	—	0.25
	0.25 – 0.4	—	0.4	—	0.4	—	0.4	—	0.4	—	0.4	—	0.4
	0.4 – 0.63	—	0.63	—	0.63	—	0.63	—	0.63	—	0.63	—	0.63
	0.63 – 1	—	1	—	1	—	1	—	1	1/2	1	1/2	0.9
	1 – 1.6	—	1.6	—	1.6	—	1.6	—	1.6	3/4	1.6	3/4	1.3
	1.6 – 2.5	—	2.5	1/2	2.5	1/2	2.4	1/2	2.2	1	2.1	1-1/2	2.4
	2.5 – 4	—	4	3/4	3.7	3/4	3.5	1	4	2	3.4	3	3.9
	4 – 6.3	3/4	6.3	1-1/2	6.3	1-1/2	6.3	1-1/2	6	3	4.8	5	6.1
	5.5 – 8	1	8	2	7.8	2	7.5	2	6.8	5	7.6	5	6.1
	7 – 10	1	8.4	—	10	—	10	3	9.6	5	7.6	7-1/2	9
	9 – 13	1-1/2	12	3	11	3	10.6	3	9.6	7-1/2	11	10	11
	12 – 18	2	13.6	5	17.5	5	16.7	5	15.2	10	14	15	17
18 – 25	3	19.2	7-1/2	25.3	7-1/2	24.2	7-1/2	22	15	21	20	22	
24 – 32	5	30.4	10	32	10	30.8	10	28	20	27	30	32	

Note 1. Since " — " has no horsepower setting by standard, select the maximum rated operating current [A].

UL Standard and SCCR

About Warranty

Type E/F Selection Table

(1) **Type E Combination**
 [Certified Rating] Combination Arrangement = Motor Circuit Breaker MMP-T32 + Power Side Terminal Cover UT-CV3 + Short-circuit Display Unit UT-TU

◆ Main Circuit Three Phase 220-240V

Type E Combination			Certified Rating				
Motor Circuit Breaker (Current Setting Range)	Power Side Terminal Cover	Short-circuit Display Unit	Maximum Rated Capacity [HP]	Maximum Rated Operating Current [A]	SCCR		
MMP-T32	UT-CV3	UT-TU	0.1 - 0.16	0.16	240V	50kA	
			0.16 - 0.25	0.25			
			0.25 - 0.4	0.4			
			0.4 - 0.63	0.63			
			0.63 - 1	1			
			1 - 1.6	1.6			
			1.6 - 2.5	1/2			2.2
			2.5 - 4	1			4
			4 - 6.3	1-1/2			6
			5.5 - 8	2			6.8
			7 - 10	3			9.6
			9 - 13	3			9.6
			12 - 18	5			15.2
			18 - 25	7-1/2			22
24 - 32	10	28					
					25kA		

Note 1. Since "-" has no horsepower setting by standard, select the maximum rated operating current [A].

◆ Main Circuit Three Phase 440-480V

Type E Combination			Certified Rating				
Motor Circuit Breaker (Current Setting Range)	Power Side Terminal Cover	Short-circuit Display Unit	Maximum Rated Capacity [HP]	Maximum Rated Operating Current [A]	SCCR		
MMP-T32	UT-CV3	UT-TU	0.1 - 0.16	0.16	480Y / 277V	50kA	
			0.16 - 0.25	0.25			
			0.25 - 0.4	0.4			
			0.4 - 0.63	0.63			
			0.63 - 1	1			
			1 - 1.6	3/4			1.6
			1.6 - 2.5	1			2.1
			2.5 - 4	2			3.4
			4 - 6.3	3			4.8
			5.5 - 8	5			7.6
			7 - 10	5			7.6
			9 - 13	7-1/2			11
			12 - 18	10			14
			18 - 25	15			21
24 - 32	20	27					
					25kA		

Note 1. Since "-" has no horsepower setting by standard, select the maximum rated operating current [A].

(2) **Type F Combination**
 [Certified Rating] Combination Arrangement = Type E Combination (See (1)) + Magnetic Contactor (Allows simplified wiring with a dedicated connecting conductor unit) S(D)-T □ /SD-Q □

◆ Main Circuit Three Phase 220-240V

Type F Combination			Certified Rating			
Type E Combination (Current Setting Range)	Magnetic Contactor	Connecting Conductor Unit	Maximum Rated Capacity [HP]	Maximum Rated Operating Current [A]	SCCR	
MMP-T32 + UT-CV3 + UT-TU	S-T10 SD-Q11 /Q12 S-T12 SD-T12 S-T20 SD-T20 S-T32 SD-T32	UT-MT20 (For S-T10/T12/T20)	0.16	240V	50kA	
		0.25	0.25			
		0.4	0.4			
		0.63	0.63			
		1	1			
		1.6	1.6			
		2.2	1/2			2.2
		4	1			4
		6	1-1/2			6
		6.8	2			6.8
		9.6	3			9.6
		9.6	3			9.6
		15.2	5			15.2
		22	7-1/2			22
28	10	28				

Note 1. Since "-" has no horsepower setting by standard, select the maximum rated operating current [A].

◆ Main Circuit Three Phase 440-480V

Type F Combination			Certified Rating			
Type E Combination (Current Setting Range)	Magnetic Contactor	Connecting Conductor Unit	Maximum Rated Capacity [HP]	Maximum Rated Operating Current [A]	SCCR	
MMP-T32 + UT-CV3 + UT-TU	S-T10 SD-Q11 /Q12 S-T12 SD-T12 S-T20 SD-T20 S-T32 SD-T32	UT-MT20 (For S-T10/T12/T20)	0.16	480Y / 277V	50kA	
		0.25	0.25			
		0.4	0.4			
		0.63	0.63			
		1	1			
		1.6	1.6			
		2.2	3/4			1.6
		4	1			2.1
		6	2			3.4
		6.8	3			4.8
		9.6	5			7.6
		9.6	5			7.6
		15.2	7-1/2			11
		22	10			14
28	15	21				
	20	27				

Note 1. Since "-" has no horsepower setting by standard, select the maximum rated operating current [A].

[Notes for adopting the product]

Before purchasing and using our products, please confirm the following product warranty.

Period and scope of warranty

● **Warranty period**

- (1) The warranty period for our products shall be one year after purchase or delivery to the designated location. However the maximum warranty period shall be 18 months after production, in consideration that the maximum length of distribution period is to be 6 months after shipping.
- (2) This warranty period may not apply in the case where the use environment or use conditions specifically impact the life of products.

● **Scope of warranty**

- (1) When any failure occurs during the above warranty period which is clearly our responsibility, we will replace or repair the failed portion of the product free of charge at the location of purchase or delivery. Note that the "failure" mentioned here shall not include such items as scratches and discoloration which do not affect performance.
- (2) In the following cases, even during the warranty period, charged repair services shall be applied.
 - ① Failures caused by inappropriate conditions, environment, handling, and uses other than those specified in catalogs, instruction manuals or specifications.
 - ② Failures caused by inappropriate installation.
 - ③ Failures caused by the design of customer's equipment or software.
 - ④ Failures caused by the customer tampering with our products such as reworks without our authorization.
 - ⑤ Failures caused by uses of the product other than ordinarily intended.
 - ⑥ Failures caused by force majeure such as fire and abnormal voltage accidents, and natural disasters such as earthquake, wind and flood.
 - ⑦ Failures caused by reasons that were unforeseeable by the level of technology at the time of shipment.
- (3) The warranty that is mentioned here shall mean warranty of the unit of delivery, and any losses induced by the failures of delivered products shall be excluded from our warranty.

● **Failure diagnosis**

In principle, primary failure diagnosis shall be conducted by the customer. However this job, if requested by the customer, can be performed by us or our service company with charge. In this case, a service fee shall be charged to the customer in accordance with our price list.

Recommendation for renewal due to life

Our Motor circuit breakers with contacts and mechanical parts have certain wear life in line with the number of open/close operations, while our mold components, coil wires, electronic parts and grease have aging degradation life influenced by the use environment and use conditions. Regarding the use of our Motor circuit breakers, we recommend customers to renew the products every 15 years as a rule, provided that the products are used in line with the number of open/close operations specified by this catalog or the instruction manual or under the standard use conditions of Molded Case Circuit Breakers and Earth-Leakage Circuit Breakers as mentioned by "The Report on Recommended Renewal Timing for Low Voltage Devices" issued by Japan Electrical Manufacturers' Association (JEMA).

Exemption from warranty related to opportunity or secondary losses.

Regardless of in or out of warranty period, loss of opportunity and lost earnings at the customer side caused by the failures of our products, any damages caused by special situation regardless of our foreseeability, secondary losses, accident compensation, damages on anything other than our products, compensation to other jobs, and damages caused by any reasons for which we are not held responsible, shall be outside the scope of our compensation.

Applicable areas of our products

- (1) The contents of products shown in this catalog are for your selection of models. When you actually use the product, read the "Instruction Manual" carefully beforehand and use correctly. Please note that the external view or specifications that should not affect the model selection can change without preannouncement.
- (2) When using a product listed in this catalog, you are required to accept that your use should not lead to any serious accident if by any chance the product develops any failures or errors, and, in the event any failure or error occurs, backup or fail-safe functions are in place outside the device by the system.
- (3) The products described in this catalog are designed and manufactured as general products to be used for general industrial fields. For this reason, the products described in this catalog should not be used for the applications requiring special quality assurance systems, such as serious public uses as atomic power plants and other power plants owned by power companies, railway applications and government and public office applications.

Note, however, that the products shall be applicable to such uses if the use is limited and the customer agrees not to require specially high quality. Furthermore, when the customer is investigating application for the uses where serious impact is foreseen to the human body and assets and therefore high reliability for security and control system is required, such as aviation, medical services, railways, combustion and fuel equipment, manned transportation equipment, entertainment facilities and security machines, please contact our representatives and discuss any necessary agreement or specifications.

Supply period of spare goods after production stop

- (1) For our Motor circuit breakers, no repairs or supply of spare parts are provided by us.
- (2) For the discontinuation of production, we will announce in such media as "Sales and Service" paper created by us.

Information of Our FA-related Products

Magnetic Starter | MS-T Series



Exceed your expectations.

- ◎10A frame model is over 16% smaller with a width of just 36mm!!
- ◎New integrated terminal covers.
- ◎Reduce your coil inventory by up to 50%.
- ◎Be certified to the highest international levels while work is ongoing to gain other country.

Product specifications

Frame	10 A to 32 A
Applicable standards	Certification to various standards including IEC, JIS, CE, UL, TÜV, CCC.
Terminal cover	Standard terminal cover improves safety, simplifies ordering, and reduces inventory, etc.
Improved wiring	Wiring and operability are improved with streamlining wiring terminal BC specifications.
Operation coil rating	Wide range of operation coil ratings reduces number of coil types from 14 (N Series) to 7 types and simplifies selection.
Option units	Diverse lineup includes Auxiliary Contact Block, Operation Coil Surge Absorber Unit, Mechanical Interlock Unit.

Low Voltage Circuit Breakers | Mitsubishi WS-V Series Molded Case Circuit Breakers, Earth Leakage Circuit Breakers



Technologies based on long year experience realize more improved performance.

- ◎The new electronic circuit breakers can display various measurement items.
- ◎Improvement of breaking performance with new breaking technology "Expanded ISTAC".
- ◎Compliance with global standard for panel and machine export.
- ◎Commoditization of internal accessories for shorter delivery time and stock reduction.

Product Specifications.

Frame	32-250A Frame
Applicable standard	Applicable to IEC, GB, UL, CSA, JIS and etc.
Expansion of UL listed product line-up	New line-up of 480VAC type with high breaking performance for SCCR requirement
Commoditization of internal accessories	Reduction of internal accessory types from 3 to 1
Commoditization for AC and DC circuit use	Common use of 32/63A frame in both AC and DC circuit
Compact size for easy to use	Thermal adjustable and electronic circuit breakers are same size as 250AF fixed type
Measuring Display Unit (MDU) breakers	MDU breakers measure, display and transmit energy date to realize energy management.

Inverter | FR-A800 Series



High-functionality, high-performance inverter

- ◎Realize even higher responsiveness during real sensor-less vector control or vector control, and achieve faster operating frequencies.
- ◎The latest automatic tuning function supports various induction motors and also sensor-less PM motors.
- ◎The standard model is compatible with EU Safety Standards STO (PLd, SIL2). Add options to support higher level safety standards.
- ◎Control and monitor inverters via CC-Link/CC-Link IE Field Network (option interface).

Product Specifications

Inverter capacity	200V class: 0.4kW to 90kW, 400V class: 0.4kW to 500kW
Control method	High-carrier frequency PWM control (Select from V/F, advanced magnetic flux vector, real sensorless vector or PM sensorless vector control), vector control (when using options)
Output frequency range	0.2 to 590Hz (upper limit is 400Hz when using advanced magnetic flux vector control, real sensorless vector control, vector control or PM sensorless vector control)
Regenerative braking torque (Maximum allowable duty)	200V class: 0.4K to 1.5K (150% at 3%ED) 2.2K/3.7K (100% at 3%ED) 5.5K/7.5K (100% at 2%ED) 11K to 55K (20% continuous) 75K or more (10% continuous), 400V class: 0.4K to 7.5K (100% at 2%ED) 11K to 55K (20% continuous) 75K or more (10% continuous)
Starting torque	200% 0.3Hz (3.7K or less), 150% 0.3Hz (5.5K or more) (when using real sensorless vector, vector control)



[Related Products]

PLC | MELSEC iQ-R Series



Revolutionary, next generation controllers building a new era in automation

- ◎High-speed, high-accuracy multiple CPU control system based on the iQ Platform
- ◎New high-speed system bus and inter-module sync realizes improved productivity and reduced TCO*
- ◎Reducing development costs through intuitive engineering (GX Works3)
- ◎Robust security features (such as security key authentication, IP filter)

Product Specifications

Program capacity	40K steps to 1200K steps
LD instruction speed	0.98 ns
Available modules	I/O, analog, high-speed counter, positioning, simple motion, network module
Control system architecture	Rack-mounted modular based system
Supported networks	Ethernet, CC-Link IE Control Network, CC-Link IE Field Network, CC-Link, RS-232, RS-422/485

*Total Cost of Ownership



HMI | Graphic Operation Terminal GOT2000 Series GT27 Model



To the top of HMIs with further user-friendly, satisfactory standard features.

- ◎Comfortable screen operation even if high-load processing (e.g. logging, device data transfer) is running. (Monitoring performance is twice faster than GT16)
- ◎Actual usable space without using a SD card is expanded to 128MB for more flexible screen design.
- ◎Multi-touch features, two-point press, and scroll operations for more user-friendliness.
- ◎Outline font and PNG images for clear, beautiful screen display.

Product Specifications

Screen size	15", 12.1", 10.4", 8.4"
Resolution	XGA, SVGA, VGA
Intensity adjustment	32-step adjustment
Touch panel type	Analog resistive film
Built-in interface	RS-232, RS-422/485, Ethernet, USB, SD card
Applicable software	GT Works3
Input power supply voltage	100 to 240VAC (+10%, -15%), 24VDC (+25%, -20%)



AC Servo | Mitsubishi General-Purpose AC Servo MELSERVO-J4 Series



Industry-leading level of high performance servo

- ◎Industry-leading level of basic performance: Speed frequency response (2.5kHz), 4,000,000 (4,194,304p/rev) encoder
- ◎Advanced one-touch tuning function achieves the one-touch adjustment of advanced vibration suppression control II, etc.
- ◎Equipped with large capacity drive recorder and machine diagnosis function for easy maintenance.
- ◎2-axis and 3-axis servo amplifiers are available for energy-conservative, space-saving, and low-cost machines.

Product Specifications

Power supply specifications	1-phase/3-phase 200V AC, 1-phase 100V AC, 3-phase 400V AC, 48V DC/24V DC
Command interface	SSCNET III/H, SSCNET III (compatible in J3 compatibility mode), CC-Link IE Field Network interface with Motion, pulse train, analog
Control mode	Position/Speed/Torque/Positioning function/Fully closed loop
Speed frequency response	2.5kHz
Tuning function	Advanced one-touch tuning, advanced vibration suppression control II, robust filter, etc.
Functional safety	Conforms to functions of IEC/EN 61800-5-2, STO: Category 3 PL d, SIL 2 Conforms to Category 4 PL e, SIL 3 by a combination with MR-D30 functional safety unit
Compatible servo motor	Rotary servo motor (rated output: 0.01 to 55kW), linear servo motor (continuous thrust 50 to 3000N), direct drive motor (rated torque: 2 to 240N*m)